

Lateral stability limits of farm tractors for
forest plantations in steep areasLimites da estabilidade lateral de tratores agrícolas
para plantações florestais em áreas inclinadasDaniel Pena Pereira¹; Nilton César Fiedler²; Julião Soares de Souza Lima³;
Maristela de Oliveira Bauer⁴; Alba Valéria Rezende⁵;
Alexandre Alves Missiaggia⁶ e João Batista Pavesi Simão⁷**Abstract**

The lateral stability of tractors to prepare land for forest plantations and maximum angles of security for the movement of farm tractors in steep areas were evaluated. The determination of these maximum inclination angles was achieved according to the position of center of gravity of the tractor and confirmed by field tests. For static equilibrium, with the tractor stopped, the limit of maximum slope was 25.10°. With the machine in motion, due to surface irregularities of the terrain and the angle of the support plan, the operational limit for the slope was 23.70°. The tractor-subsoiler reached 87.89% of the area estimated for the maximum inclination of 23.70° in mechanical tillage, with a safety factor of 50%. The slope and surface roughness of the terrain limited the performance of moving machinery for soil preparation for forestry, and the subsoiling resulted in 88% of the area defined by the slope limit of 23.70°.

Keywords: Steep slope forestation, Lateral safety stability of tractors, Forest operations, Mechanization, Silviculture

Resumo

Neste estudo, avaliou-se a estabilidade lateral de tratores no preparo do solo para plantações florestais e determinou-se o ângulo máximo de segurança para a circulação de tratores agrícolas em áreas declivosas. A determinação desse ângulo máximo de inclinação foi atingida de acordo com a posição do centro de gravidade do trator e confirmada por testes de campo. Para o equilíbrio estático, com o trator parado, o limite de inclinação máxima foi calculada em 25,10°, acima desse valor o trator tomba de lado. Com a máquina em movimento, as irregularidades da superfície do terreno podem mudar o ângulo do plano de apoio, e, assim, obteve-se o limite de inclinação operacional de 23,70°. No plantio mecanizado, o conjunto trator-subsolador atingiu 87,89% da área estimada pela inclinação máxima de 23,70°, considerando um coeficiente de segurança de 50%. Concluiu-se que a rugosidade da superfície e inclinação do terreno foram limitantes para o desempenho das máquinas no preparo do solo para as culturas florestais e a subsolagem resultou em praticamente 88% da área definida pelo limite de inclinação de 23,70°.

Palavras-chave: Florestamento em encostas íngremes, Segurança da estabilidade lateral de tratores, Operações florestais, Mecanização, Silvicultura

¹Forestry Department of Espírito Santo Federal University – Centro de Ciências Agrárias, Alto Universitário, s/n° - Cx Postal 16 - Alegre, ES – Brazil - 29500-000. Telephone-Fax: 55 28 3511 9809; Cellular telephone: 55 28 9946 9201; E-mail: daniel@geraes.org

²Forestry Department of Espírito Santo Federal University – Centro de Ciências Agrárias, Alto Universitário, s/n° - Cx Postal 16 - Alegre, ES – Brazil - 29500-000; E-mail: fiedler@pq.cnpq.br

³Forestry Department of Espírito Santo Federal University – Centro de Ciências Agrárias, Alto Universitário, s/n° - Cx Postal 16 - Alegre, ES – Brazil - 29500-000; E-mail: limajss@yahoo.com.br

⁴Forestry Department of Espírito Santo Federal University – Centro de Ciências Agrárias, Alto Universitário, s/n° - Cx Postal 16 - Alegre, ES – Brazil - 29500-000; E-mail: bauerermo@terra.com.br

⁵Technology Faculty of Brasília University - Forestry Department-FT-UNB, Asa Norte, Cx Postal 4357, Brasília, DF – Brasil, CEP 70910-900; E-mail: albavr@unb.br

⁶Fibria Celulose S.A. - Rodovia Aracruz x Barra do Riacho km 25 – Aracruz, ES – Brasil, CEP 29.197-900; E-mail: amissiaggia@fibria.com.br

⁷Federal Institute of Higher Education – IFES Campus de Alegre – Rodovia Alegre x Jerônimo Monteiro s/n°, Alegre, ES – Brazil - CEP 29500-000; E-mail: jbpavesi@ifes.edu.br

INTRODUCTION

Worldwide a large number of fatalities occur involving agricultural tractors operating on steep areas (HUNTER; OWEN, 1983). Statistics indicate causes ranging from lack of training of machine operators, lack of attention to equipment failures and instability of the ground. Successful agricultural activities in areas of steep topography require attention to safety regulations, which, among other things, consider the slope of the surface and the stability of the machines used (CHISHOLM, 1979; MASHADI; NASROLAHI, 2009).

Slope is a limiting factor for safe use of farm tractors in steep terrain, and both knowledge of the maximum angle of lateral stability of the tractors and the zoning where farming operations are performed are important for planning. Longitudinal and lateral stability are related to the ability of a machine to ascend and descend a slope in the transverse direction without compromising the ability to drive (LIMA *et al.*, 2004). Loss of stability is a major factor contributing to the overturning of tractors on these lands (GIALAMAS *et al.*, 2006; GILFILLAN, 1967; HUNTER, 1981; SPENCER, 1978).

In most forest plantations in Brazil, only restricted tillage is performed, with soil mobilization exclusively on the planting row or pit, allowing for fast root growth, and consequently greater efficiency in the use of water and nutrients adjacent to plants. The most

commonly used implements in areas managed under the reduced soil tillage system are the subsoiler, chisel plow and pit digger. Due to its greater operational capacity and low cost, subsoiling is the operation most commonly employed to prepare forest soils in Brazil (SASAKI *et al.*, 2007).

This survey studied the use of tractors to prepare soil on sloping ground, showing areas suitable and unsuitable for tractor use, while pulling a subsoiler. Geographic information system (GIS) and the manufacturer's recommendations regarding the static equilibrium of the tractor were used.

MATERIALS AND METHODS

The study area was located in the district of São José do Calçado, southern Espírito Santo State, Brazil, on a 9.74 ha area (Figure 1). The study area lies between the coordinates $-20^{\circ}55'60''$ N, $-20^{\circ}56'13''$ S, $-41^{\circ}37'41''$ E, and $-41^{\circ}38'00''$ W (DATUM GCS South American 1969). The trial was performed on a 36.5% medium slope site with a north and a northeast exposure. The soil in the study area is a dystrophic Red-Yellow latossol soil (oxisol), commonly found in Brazil.

Topographic data were derived from a digital elevation model (DEM) obtained by the collection of features and elevation coordinates (coordinates x, y and heights z) by 780 points in the study area. The manipulation and analysis of data determined from the DEM, contour lines, and classes of terrain slope were performed.

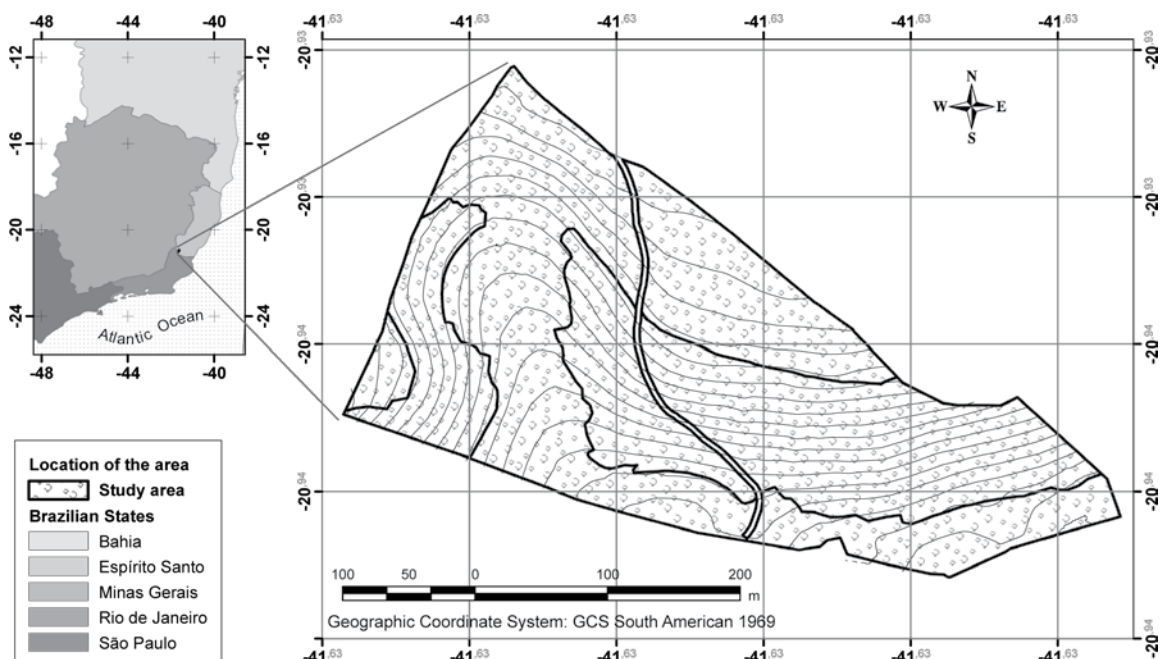

Figure 1. Geographical location of study area.

Figura 1. Localização geográfica da área de estudo.

This study used a tractor with an engine power of approximately 112 kW, backed with 455 kg of iron ballasts on the front and 150 kg in each rear wheel, with a total weight of approximately 6.265 kg. The tractor had about 12 years use, was well maintained and the tires were at half life.

The tractor pulled a subsoiler fertilizer-trawler, single stem without wing, with a small set of disks in the back; preparing the soil at an average depth of 50 cm. This type of agricultural tractor plus subsoiler is widely used in forestry, mainly by small and medium sized farms. The tractor's gauge was at most 2.04 m and the total tractor width was 2.50 m, front wheel assist and all tires ballasted with water. The coordinates of the center of gravity (CoG) were provided by the technical specification of the tractor: X = 1226.91 mm, Y = 850.00 mm, and Z = -5.20 mm (Figure 2).

The study was conducted with the tractor in lateral static equilibrium, as seen in Equation 1. Its relationship around the support plan was determined by the vertical and horizontal components of the total force weight passing through the CoG of the tractor, according to literature methodology (MIALHE, 1980; SACK, 1956) and adopted by Lima *et al.* (2004):

$$\beta = (\tan^{-1} S/2y) \times f(1)$$

Where:

- β = slope limit of the support plan in degrees;
- S = tractor's gauge in millimeters;
- y = vertical coordinate of gravity center in millimeters;
- f = safety factor equal 50% or f = 0.5.

Equation 1 shows the condition of static equilibrium of the tractor when the slope of the support plan is equal to . If this value is exceeded, theoretically the tractor tips sideways. Even within

this limit, obstacles may be encountered in the path of the tractor, changing the angle of the plane of the tractor and causing it to fall over. The slope operating limit (β_{max}) recommends the maximum movement, accommodating changes to the ground surface, constant or sudden, causing asymmetry between the points of contact of the tires with the ground, due to either the wheels rolling in grooves or irregularities in the ground surface (MIALHE, 1980). Thus, according to Equation 2, there is an extension of the margin of safety, considering terrain irregularities with a potential risk for safe lateral movement of the tractor:

$$\beta_{max} = (\tan^{-1} \frac{(S)^2 - P}{2y \times S + P}) \times f(2)$$

Where:

- β_{max} = slope operating limit in degrees;
- y = vertical coordinate of gravity center in millimeters;
- S = tractor's gauge in millimeters;
- P = height of the unevenness of the support plan of the tractor in millimeters;
- f = safety factor equal 50% or f = 0.5.

In practice, long before reaching this slope, the tractor is in serious danger of losing lateral stability. To that end, we applied a safety factor of f, giving the boundary condition of dynamic equilibrium for a given tractor. This is because at higher speed, a stronger action of the dynamic processes can induce a rollover of the machine (MIALHE, 1980). As a safety standard, we recommend using half the value of the angle of inclination of slope limits, to determine the maximum slope of an area that the tractor-subsoiler should work on. Therefore, the safety factor was set at 50% (f = 0.5).

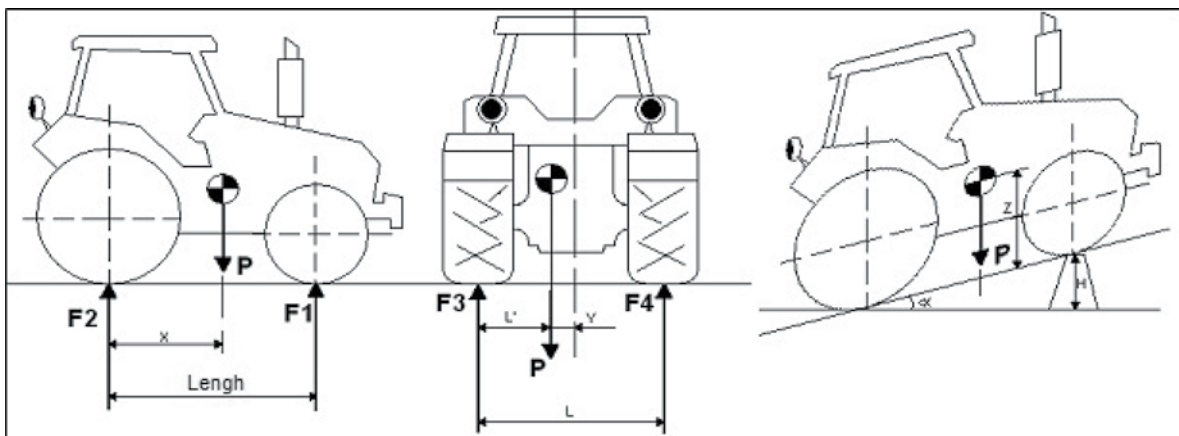

Figure 2. Diagram of the tractor used in the study and its coordinates X, Y, and Z used for the calculation of its gravity center (CoG).

Figura 2. Diagrama do trator usado e suas coordenadas X, Y e Z usadas para o cálculo do seu centro de gravidade (CoG).

Theoretical analysis was then performed on sub soiling in the area, determining the total area prepared with the tractor-subsoiler operating on contours. Subsequently, thematic maps with the definition of areas suitable and unsuitable for use of the tractor were made through the command reclassify, to determine the total value of each area in square meters, as well as its percentage. The spatial resolution of raster images used was 1 m.

RESULTS AND DISCUSSION

Knowing the coordinates of the CoG given by Zanotto (ZANOTTO, 2008) and the gauge of the tractor, we determined the slope of the plane according to Equation 1 at static equilibrium. The slope operational limit for static movement of the tractor-subsoiler was:

$$\beta = (\tan^{-1} \frac{2040}{2 \times 850}) \times 0.5 = 25.1^\circ$$

However, the ground surface, especially in steep areas with little or infrequent soil tillage, is very irregular. Tractor tipping is likely if obstacles such as termite mounds, crop residues or ridges are found. These obstacles can be unobtrusive and unseen by the operator. In spite of not having been considered here, the roughness of the terrain can influence the movement of tractors on different slope classes.

Equation 2 has widened the margin of safety by including an occasional obstacle height of 150 mm and the safety factor, as found on the study site. The slope operational limit for dynamic movement of the tractor-subsoiler was as follows:

$$\beta_{max} = (\tan^{-1} \frac{\frac{(2040)^2}{2 \times 850} - 150}{\frac{150 \times 2040}{2 \times 850} + 2040}) \times 0.5 = 23.7^\circ$$

The condition of static equilibrium was then changed to the lateral boundary condition with a dynamic equilibrium value of 23.7° or the equivalent slope limit of 43.9%. The thematic maps relating to the areas suitable for theoretical analysis and those determined in practice are given, respectively, in Figures 3 and 4.

Oliveira *et al.* (2005) found similar results, with an estimated maximum angle varying between 21.3° and 22.3°, on steep areas in southern Espirito Santo state, Brazil. A different range was found in the recommended limit of inclination for tractor movement in the country side of Minas Gerais state, Brazil, where Souza *et al.* (2004) noted the threshold for toppling to be 17.5°, equivalent to a 31% slope, for a tractor with similar CoG. This was consistent with the manufacturer's recommendations, which indicated the maximum inclination of 16.7°, or a 30% slope.

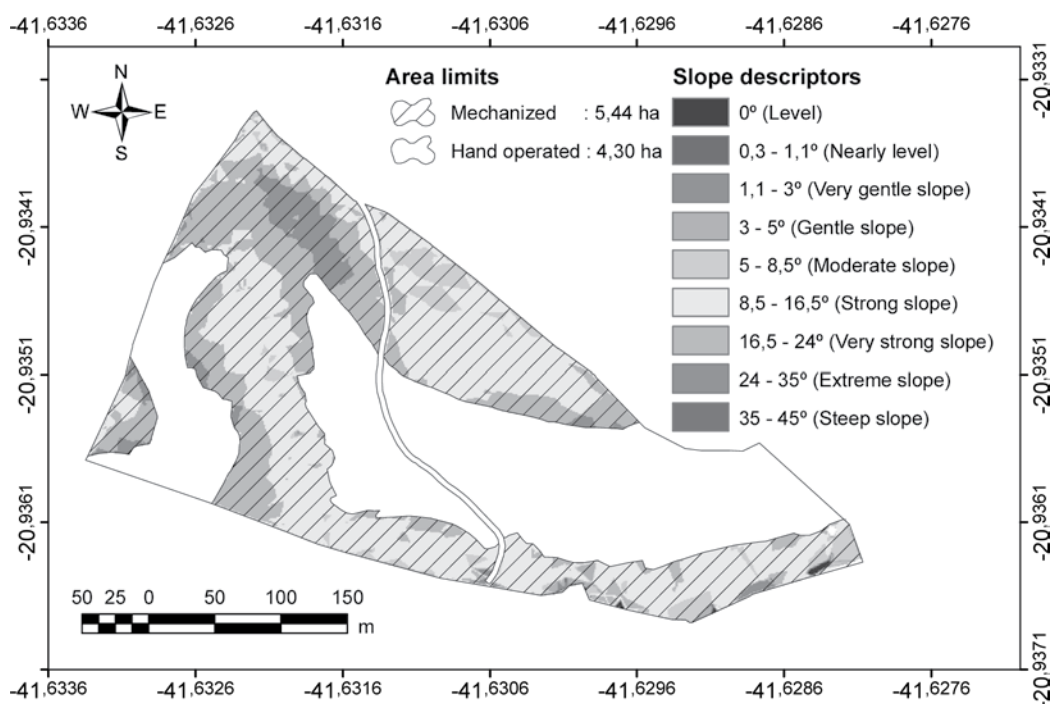

Figure 3. Movement carried out by the tractor-subsoiler.

Figura 3. Tráfego do conjunto trator-subsolador realizado na operação de subsolagem na área.

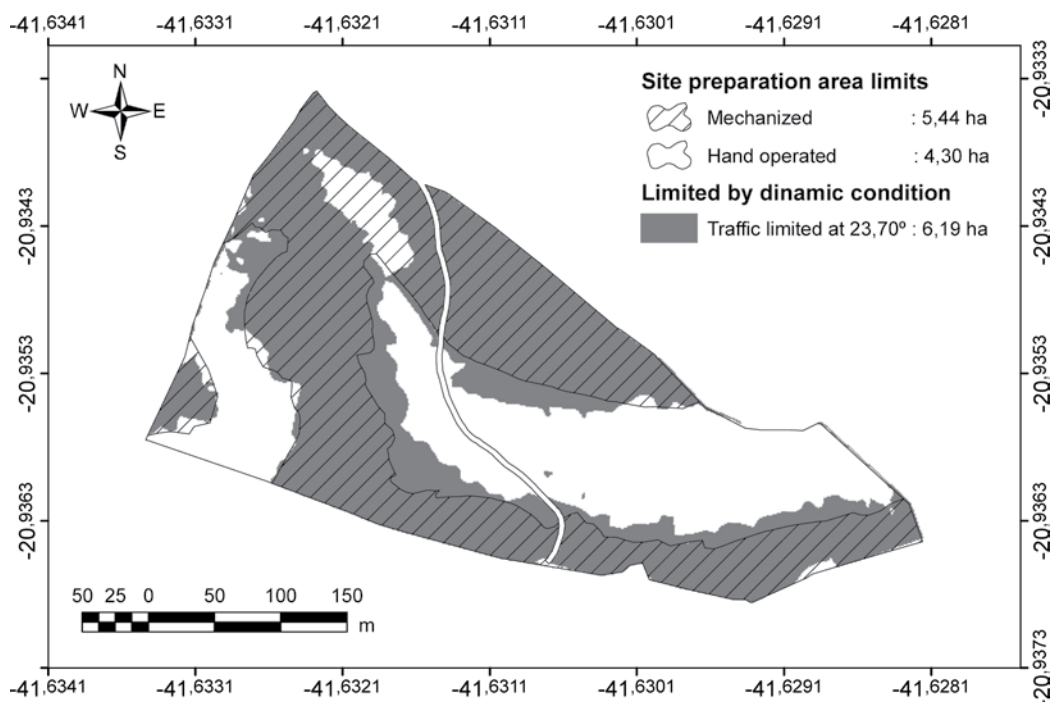

Figure 4. Overlapping areas with subsoiling: carried out vs. recommended.
Figura 4. Sobreposição de áreas com a subsolagem realizada x recomendada.

Different results for machine movement on slopes were reported by Valverde (1995) and Lima *et al.* (2004). For a Skidder, Valverde (1995) found the slope limit to be 19.3°, while Lima *et al.* (2004) observed an 18.4° inclination limit for the same tractor and 13.1° for the Feller-Buncher, which carries bundles of trees on the front head, causing greater instability in the transverse plane.

Sub soiling reached 81.61% of the area stipulated by the slope limit for static equilibrium. Regarding dynamic equilibrium; the area obtained in practice reached the limits of the theoretical field limit set by the slope at 87.89%, as seen in Figure 4.

The area subsoiled reached 5.44 ha rather than the 6.19 ha recommended by the limit for an inclination of 23.7°. This was about 18% below the area of 6.67 ha, bounded by the condition of static equilibrium calculated at

25.1°, or the equivalent slope limit of 46.84%, with a safety factor equal to 50%. These results were possible due to the experience and the skill of the operator. In Table 1, we observe the percentage of area passable by tractor-subsoiler, with the slope limits for relief classes in different situations.

Because subsoiling is an operation that demands more traction force for work in forests and because it is more susceptible to accidents on slopes; sub soiling defined the theoretical limits of the areas for mechanized farming, from the slope limit of 23.7° or the equivalent slope limit of 43.9% (Figure 3).

Notably, if the safety factor for the static condition for the dynamics of movement is less than 50%, as used in Equation 3, we can achieve 100% of the theoretical limit. The safety factor of 46.2% enables this setting, provided that the sub soiling area reaches the theoretical limit of

Table 1. Simulation of tractor-subsoiler operation at different limits.

Tabela 1. Simulação da operação do conjunto trator-subsolador sob diferentes limites.

Limitation	Slope operating limit (degrees)	Estimated operation (ha)	%	Operation ability held (ha)	%
Static condition	0-25.10	6.67	68.48	5.44	81.61
	> 25.10	hand operated	31.52	-	-
	Total	9.74	100	-	-
Dynamic condition	0-23.70	6.19	63.55	5.44	87.89
	> 23.70	hand operated	36.45	-	-
	Total	9.74	100	-	-
Limit set	0-21.90	5.44	55.85	5.44	100
	> 21.90	hand operated	44.15	-	-
	Total	9.74	100	-	-

21.9°, or the equivalent slope limit of 40.2%, which serves as a reference for the tractor lateral movement in slope areas. Even though the tractor could work in these areas with greater slope, these limits should be checked if they are acceptable for soil conservation (GONÇALVES, 2002).

Knowledge of equilibrium conditions allows a safe use of tractors, avoiding risk of accidents on lands with sloping topography. We calculated the percentage of the area that can safely be tilled with mechanized machinery (subsoiling), while providing a wide safety margin.

CONCLUSIONS

1. Given the importance of forest plantations on steep areas for farmers, it is possible to safely prepare the soil with contour sub soiling up to 23.7° slope;
2. The slope and surface roughness of the terrain were limiting for the traffic performance of the tractor-subsoiler; thus sub soiling resulted in 88% of the area defined by the slope limit of 23.7°;
3. To prepare soil with sub soiling on contour in steep areas, it is important to emphasize the need to adjust the gauge for maximum opening, as observed in this work, for better dynamic equilibrium conditions;
4. Knowing the slope limit for traffic and using a digital elevation model, it is possible to calculate the percentage area to undergo mechanical tillage safely on steep lands.

REFERENCES

CHISHOLM, C.J. A mathematical model of tractor overturning and impact behavior. *Journal of Agricultural Engineering Research*, London, v.24, p.375-394, 1979.

GIALAMAS, T.H.A.; BOCHTIS, D.; AMPATZIDIS, Y.; KATERIS, D.; GEMTOS, T.H.A.; TSATSARELIS, C.A. Tractor Stability Estimation Using Adjusting Testing-Bench. In: PROCEEDINGS OF THE INTERNATIONAL CONFERENCE ON INFORMATION SYSTEMS IN SUSTAINABLE AGRICULTURE, AGROENVIRONMENT AND FOOD TECHNOLOGY, 3, 2006, Volos. *Proceedings...Volos: HAICTA*, 2006. p.179-186.

GILFILLAN, G. Attitude of a tractor on sloping land. *Journal of Agricultural Engineering Research*, London, v.12, n.4, p.293-296, 1967.

GONÇALVES, J.L.M. Conservação do solo. In: GONÇALVES, J.L.M.; STAPE, J.L. (Eds.). *Conservação e Cultivo de Solos Para Plantações Florestais*. Piracicaba: IPEF, 2002. p.47-129.

HUNTER, A.G.M. Tractorsafety on slopes. *Agricultural Manpower*. Haslemere, v.36, n.4, p.95-98, 1981.

HUNTER, A.G.M.; OWEN, G.M. Tractor overturning accidents on slopes. *Journal of Occupational Accidents*, Amsterdam, v.5, p.195-210, 1983.

LIMA, J.S.S.; SOUZA, A.P.; MACHADO, C.C.; PEZZOPANE, J.E.M.; AREAS, M.L. Estimativa das estabilidades longitudinal e transversal de tratores florestais utilizados na colheita de madeira. *Revista Arvore*, Viçosa, v.28, n.6, p.839-844, 2004.

MASHADI, B.; NASROLAHI, H. Automatic control of a modified tractor to work on steep side slopes. *Journal of Terramechanics*, Oxford, v.46, p.299-311, 2009.

MIALHE, L.G. Condições de equilíbrio e transferência de peso nos tratores agrícolas. In: _____ *Máquinas Motoras na Agricultura*. 2ed. São Paulo: EDUSP, 1980. p.293-302.

OLIVEIRA, R.B.; XAVIER, A.C.; QUARTO JUNIOR, P.; SILVA, A.F.; LIMA, J.S.S. Mapeamento das áreas aptas para tráfego de tratores agrícolas no município de Alegre-ES. In: ENCONTRO LATINO AMERICANO DE PÓS-GRADUAÇÃO, 5 e ENCONTRO LATINO AMERICANO DE INICIAÇÃO CIENTÍFICA, 9, 2005, São José dos Campos. *Anais... São José dos Campos: UNIVAP*, 2005. v.1, p.596-598.

SACK, H.W. Longitudinal stability of tractors. *Agricultural Engineering*, Romania, v.37, n.5, p.328-333, 1956.

SASAKI, C.M.; GONÇALVES, J.L.M.; SILVA, A.P. Ideal subsoiling moisture content of Latosols used in forest plantations. *Forest Ecology and Management*, Amsterdam, v.243, n.1, p.75-82, 2007.

SOUZA, L.H.; VIEIRA, L.B.; FERNANDES, H.C.; LIMA, J.S.S; KHOURY JUNIOR, J.K. Determinação da estabilidade lateral de um conjunto trator-recolhedora de feijão para o trabalho de campo. **Engenharia na Agricultura**, Botucatu, v.12, n.1, p.66-71, 2004.

SPENCER, H.B. Stability and control of two-wheel drive tractors and machinery on sloping ground. **Journal of Agricultural Engineering Research**, London, v.23, n.2, p.169-188, 1978.

VALVERDE, S.R. **Análise técnica e econômica do sistema de colheita de árvores inteiras em povoamentos de eucalipto**. 1995. 123p. Dissertação (Mestrado em Engenharia Florestal) – Universidade Federal de Viçosa, Viçosa, 1995.

ZANOTTO, R. **Center of gravity**. Valtra AGCO Corporation. [Mensagem pessoal]. Mensagem recebida por: <daniel@geraes.org>. Acesso em: 17 nov. 2008.

Recebido em 25/10/2010
Aceito para publicação em 13/10/2011

